

INDICATES CROSS BRACING

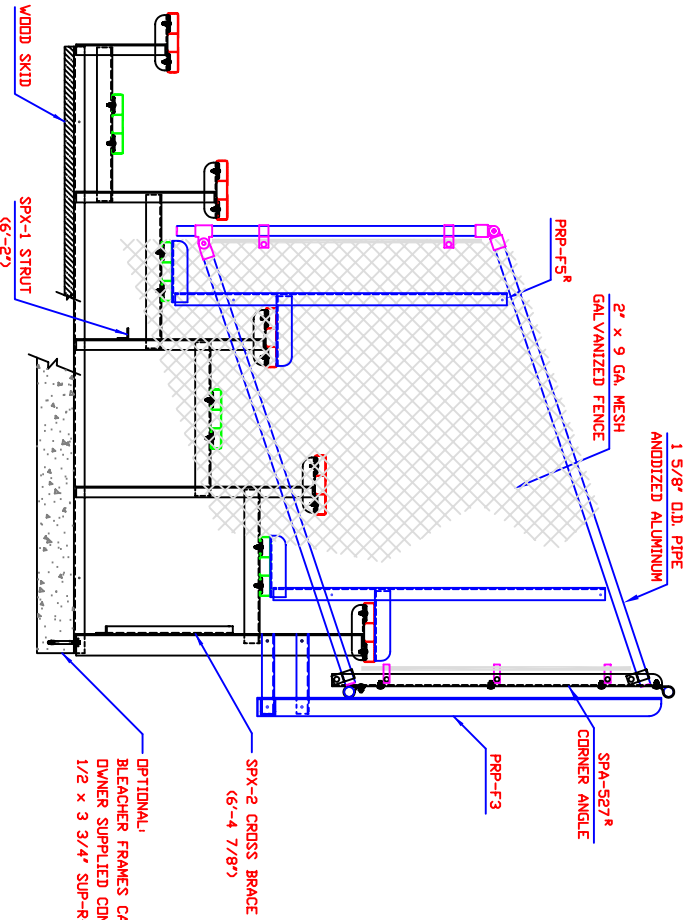

OPTIONAL!
BLEACHER FRAMES CAN BE ATTACHED TO
OWNER SUPPLIED CONCRETE PAD USING
1/2 x 3 3/4" SUP-R-STUDS (NOT INCLUDED)

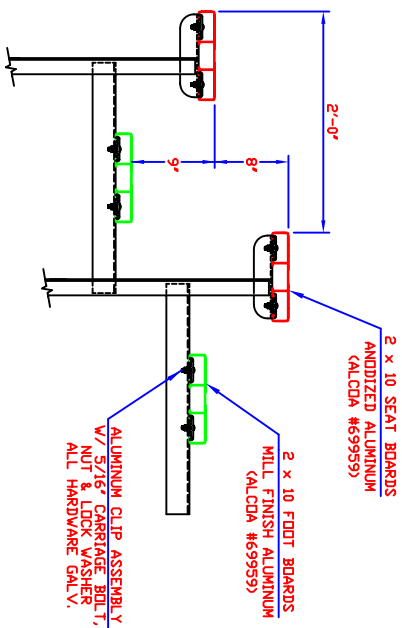

PLANK ARRANGEMENT

SEATING CAPACITY
@ 18' PER SEAT = 50

END ELEVATION
ALL FRAMING & BRACING ANGLES 1 3/4 x 1 3/4 x 3/16
ALL STRUTS & BRACING ANGLES 1 1/4 x 1 1/4 x 3/16
ALL ALUMINUM FOOT BOARD ANGLES 2 1/2 x 2 x 3/16
UNLESS NOTED

ALUMINUM 6061-T6 UNDERSTRUCTURE
THIS DRAWING INCLUDING THE DIMENSIONS OR DESIGN
SPECIFICATIONS IS THE PROPERTY OF B & D
SPECIALTY STANDS, INC. WITH THE AGREEMENT THAT
IT IS NOT TO BE REPRODUCED, COPIED OR LINKED IN
PART OR WHOLE, NOT TO BE USED IN ANY MANNER
WHICH IMPLICATES OR ENDORSES B & D SPECIALTY
STANDS, INC. WITHOUT THE WRITTEN CONSENT AND
AGREEMENT TO THE ABOVE.

SCALE	3/4"=1'-0"
DATE	3/10/04
BY	DK
CHECKED BY	

**END ELEVATION & PLAN VIEW
5 ROW UNIT
STANDARD PORTABLE**
B & D SPECIALTY STANDS, INC.
NORTH COLLINS, NEW YORK
P524-15-H

LETTER	REVISIONS	BY	DATE