

LETTER	REVISIONS	BY	DATE

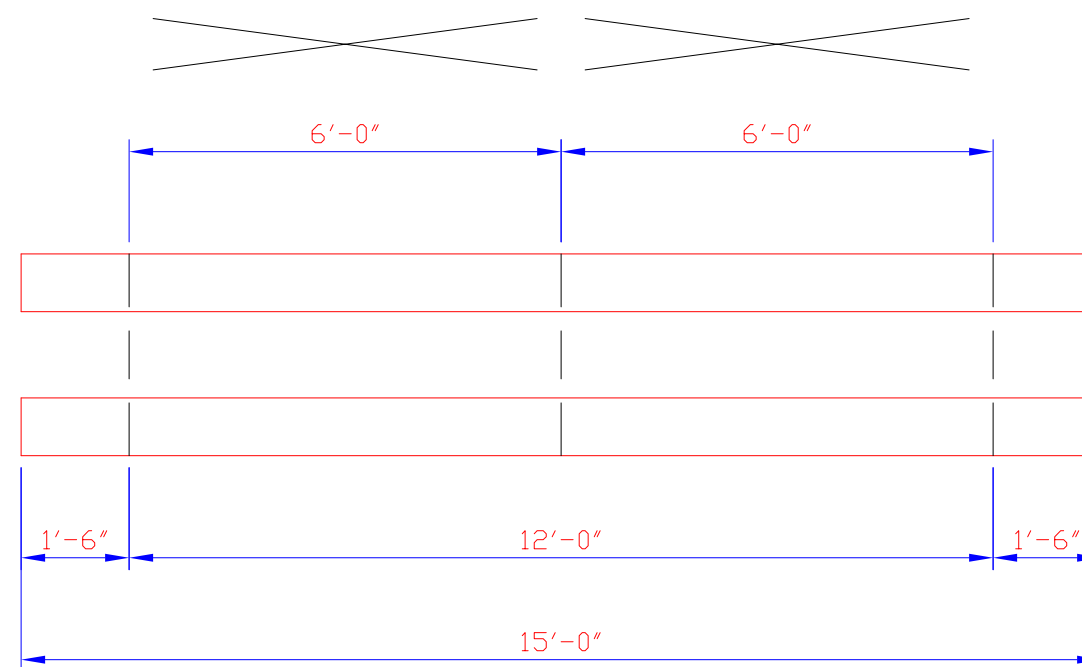

INDICATES CROSS BRACING

PLAN OF BLEACHER
(1/4 SCALE)

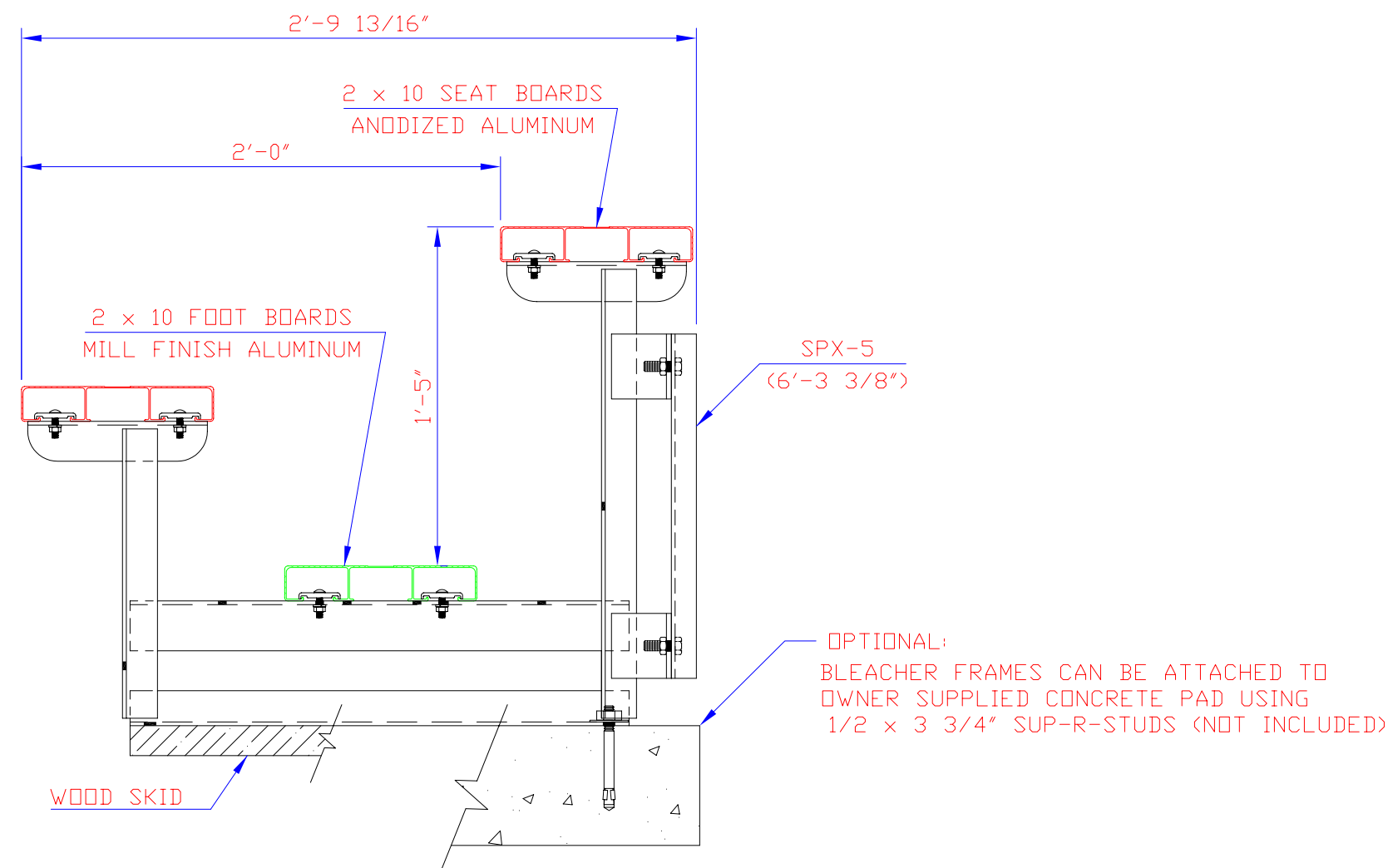

END ELEVATION

ALL FRAMING ANGLES 1 3/4 x 1 3/4 x 3/16"
 ALL STRUTS & BRACING ANGLES 1 1/4 x 1 1/4 x 3/16"
 ALL ALUMINUM FOOT BOARD ANGLES 2 1/2 x 2 x 3/16"
 UNLESS NOTED

SEATING CAPACITY
 @ 18" PER SEAT = 20

ALUMINUM 6061-T6 UNDERSTRUCTURE		SCALE 1 1/2"=1'	REFERENCE DWG.	END ELEVATION & PLAN VIEW 2 ROW UNIT STANDARD PORTABLE
THIS DRAWING INCLUDING THE PRINCIPLES OF DESIGN IS THE PROPERTY OF AND IS SUBMITTED BY E & D SPECIALTY STANDS, INC. WITH THE AGREEMENT THAT IT IS NOT TO BE REPRODUCED, COPIED OR LOANED IN PART OR WHOLE, NOT TO BE USED IN ANY MANNER THAT MAY CONSTITUTE A DETRIMENT DIRECTLY OR INDIRECTLY TO E & D SPECIALTY STANDS, INC. ACCEPTANCE OF THIS DRAWING WILL BE CONSTRUED AS AN AGREEMENT TO THE ABOVE.		DRAWN BY D.K.	CHECKED BY	
		DATE 1/23/04	DATE	
		E & D SPECIALTY STANDS, INC. NORTH COLLINS, NEW YORK		