

LETTER	REVISIONS	BY	DATE

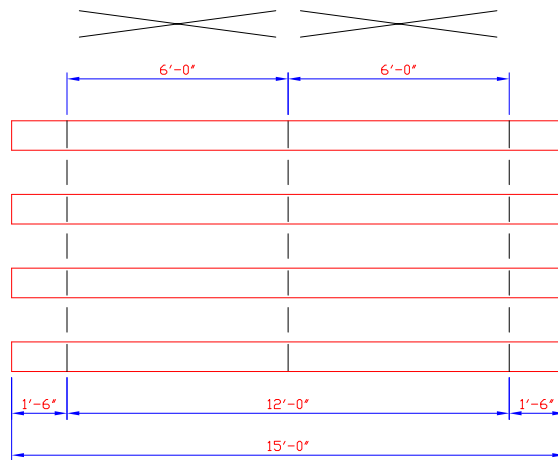

PLAN OF BLEACHER
(1/4 SCALE)

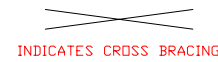

INDICATES CROSS BRACING

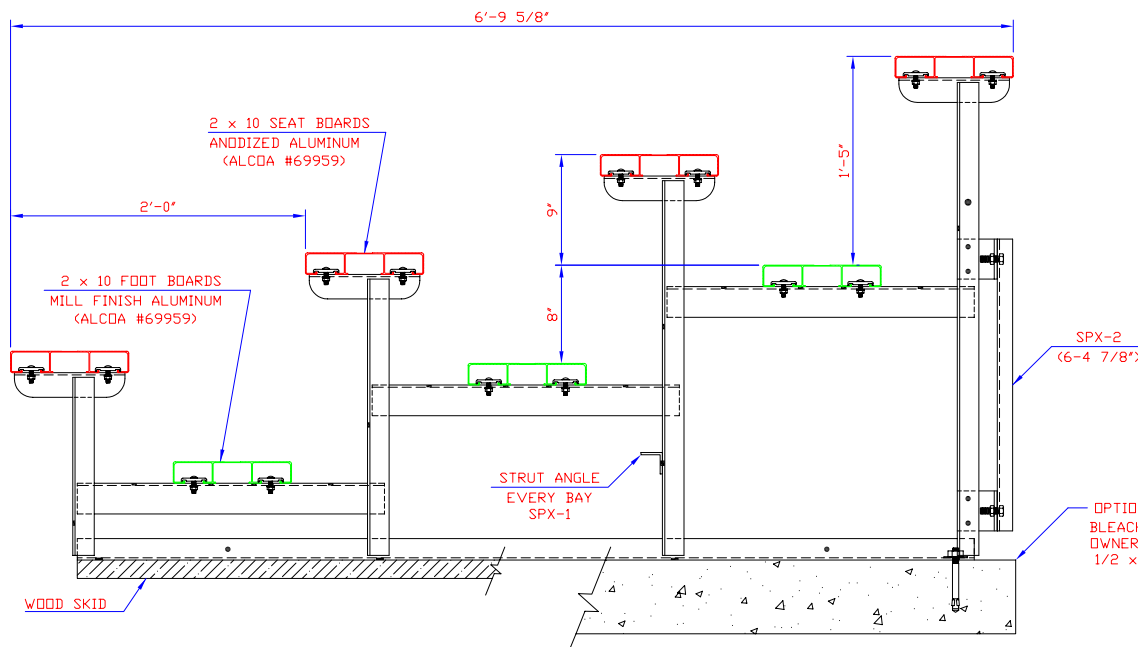

OPTIONAL:
BLEACHER FRAMES CAN BE ATTACHED TO
OWNER SUPPLIED CONCRETE PAD USING
1/2 x 3 3/4" SUP-R-STUDS (NOT INCLUDED)

SEATING CAPACITY
@ 18" PER SEAT = 40

END ELEVATION

ALL FRAMING ANGLES 1 3/4 x 1 3/4 x 3/16"
ALL STRUTS & BRACING ANGLES 1 1/4 x 1 1/4 x 3/16"
ALL ALUMINUM FOOT BOARD ANGLES 2 1/2 x 2 x 3/16"
UNLESS NOTED

ALUMINUM 6061-T6 UNDERSTRUCTURE	SCALE	REFERENCE DWG.	END ELEVATION & PLAN VIEW 4 ROW UNIT STANDARD PORTABLE
	1/2"=1'		
	DRAWN BY	CHECKED BY	
	D.K.		
THIS DRAWING INCLUDING THE PRINCIPLES OF DESIGN IS THE PROPERTY OF AND IS SUBMITTED BY E & D SPECIALTY STANDS, INC. WITH THE AGREEMENT THAT IT IS NOT TO BE REPRODUCED, COPIED OR LOANED IN PART OR WHOLE, NOT TO BE USED IN ANY MANNER THAT MAY CONSTITUTE A DETRIMENT DIRECTLY OR INDIRECTLY TO E & D SPECIALTY STANDS, INC. ACCEPTANCE OF THIS DRAWING WILL BE CONSTRUED AS AN AGREEMENT TO THE ABOVE.	DATE	DATE	E & D SPECIALTY STANDS, INC. NORTH COLLINS, NEW YORK
	1/30/04		
			P424-15