

LETTER	REVISIONS	BY	DATE

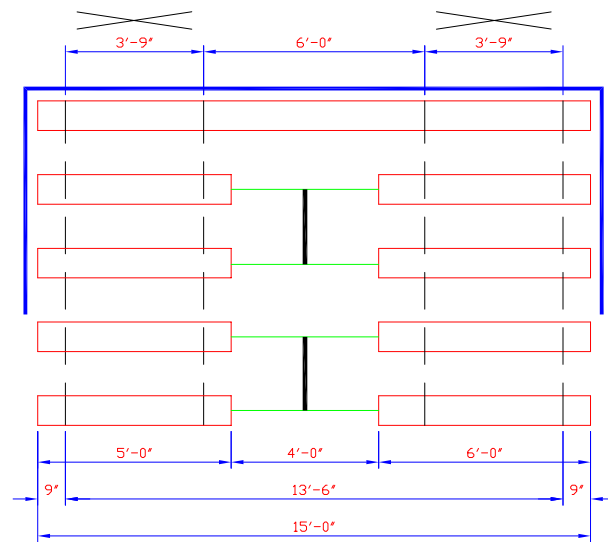
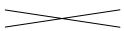

PLAN OF BLEACHER

1/2 SCALE

 INDICATES CROSS BRACING

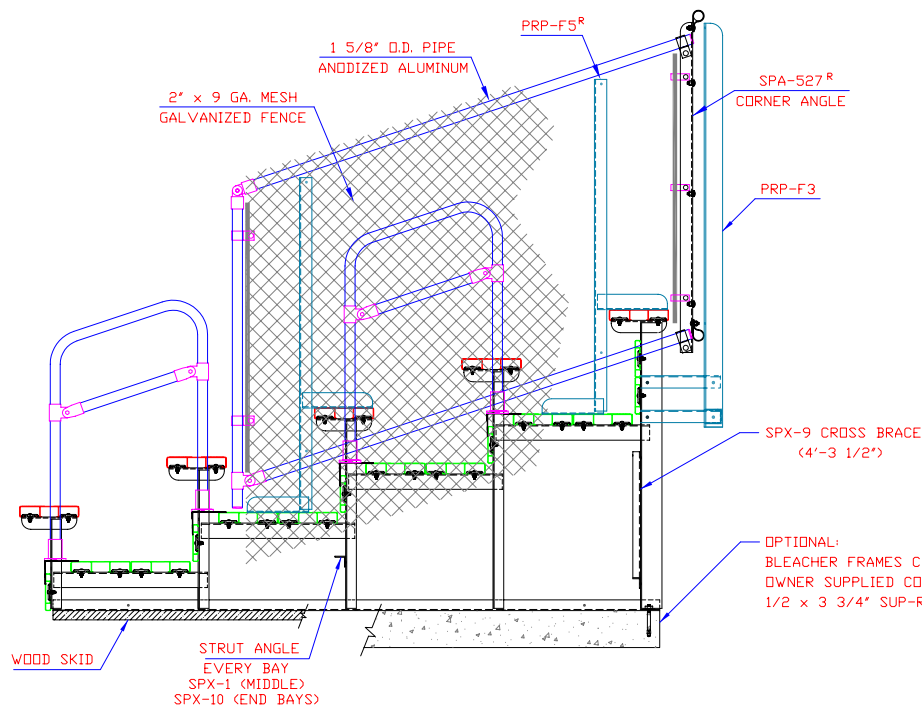

END ELEVATION

ALL FRAMING & BRACING ANGLES 1 3/4 x 1 3/4 x 3/16
 ALL STRUTS & BRACING ANGLES 1 1/4 x 1 1/4 x 3/16
 ALL ALUMINUM FOOT BOARD ANGLES 2 1/2 x 2 x 3/16
 UNLESS NOTED

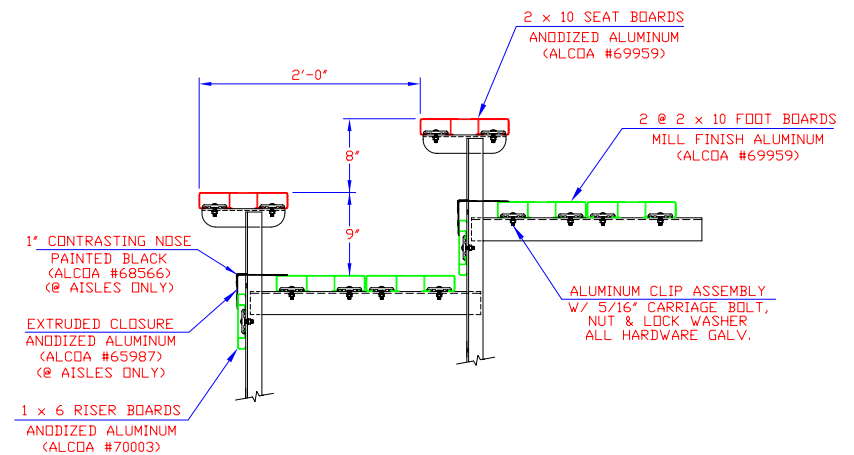

PLANK ARRANGEMENT
FULL PLANK DECK SERIES

SEATING CAPACITY
@ 18" PER SEAT = 38

ALUMINUM 6061-T6 UNDERSTRUCTURE	SCALE	3/4"=1'-0"	REFERENCE DWG.	END ELEVATION & PLAN VIEW 5 ROW PORTABLE w/CENTER AISLE (2) FOOT BOARDS w/ RISERS
	DRAWN BY	D.K.	CHECKED BY	
THIS DRAWING INCLUDING THE PRINCIPLES OF DESIGN IS THE PROPERTY OF AND IS SUBMITTED BY E & D SPECIALTY STANDS, INC. WITH THE AGREEMENT THAT IT IS NOT TO BE REPRODUCED, COPIED OR LOANED IN PART OR WHOLE, NOT TO BE USED IN ANY MANNER THAT MAY CONSTITUTE A DETRIMENT DIRECTLY OR INDIRECTLY TO E & D SPECIALTY STANDS, INC. ACCEPTANCE OF THIS DRAWING WILL BE CONSTRUED AS AN AGREEMENT TO THE ABOVE.	DATE	3/10/04	DATE	
	E & D SPECIALTY STANDS, INC. NORTH COLLINS, NEW YORK			P524-15-HAL